

## Clapets de pied

### Type 102 102P

**Rp 2 1/4" – Rp 8"**

Crépine: Acier galvanisé PP

#### Données techniques

<b>Système de fermet.:</b>	02
<b>Pression de service:</b>	$P_{max}$ [bar] voir les tableaux [mm]
<b>Raccordement:</b>	Taraudé femelle
<b>Fluide:</b>	Liquides, neutres, propres
<b>Temp. de fluide:</b>	302 / 302 SKV4A -10°C / +100°C 302P -10°C / +80°C
<b>Position de mont.:</b>	Verticale en haut (seulement!) En cas de conduite horizontale, veuillez utiliser le type 402 avec une crépine séparée.



#### Type 102 (Crépine acier galvanisé)

Art.-No.	Rp	H	H2	D	Kv [m3/h]
2766	2 1/4"	167	123	97	82
2767	2 1/2"	167	124	97	82
2768	3"	212	152	125	120
2769	4"	251	180	150	188
1162	5"	345	230	188	291
1163	6"	430	2275	223	490
1164	7"	508	333	266	594
1165	8"	508	333	266	594

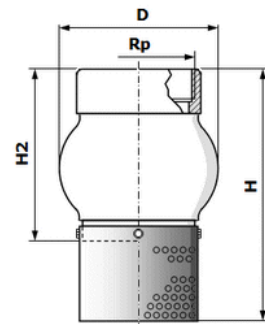

#### Type 102 (Crépine PP)

Art.-No.	Rp	H	H2	D	Kv [m3/h]
2758	2 1/4"	167	123	97	82
2759	2 1/2"	167	124	97	82
2760	3"	212	152	125	120
2761	4"	251	180	150	188

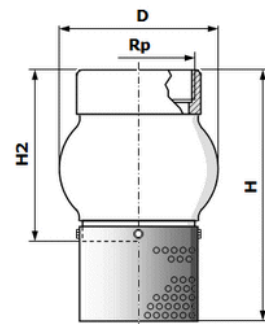

#### Options sur demande:

- autres matériaux
- autres joints

## Matériaux

Type →	102		102P	
1 <b>Corps:</b>	GG25, epoxy		GG25, epoxy	
2 <b>Axe:</b>	Bronze		Bronze	
3 <b>Guide:</b>	Rp 2¼" – 2½" Rp 3" – 8"	Bronze GG25, epoxy	Rp 2¼" – 2½" Rp 3" – 8"	Bronze GG25, epoxy
4 <b>Bague:</b>	Bronze		Bronze	
5 <b>Ressort:</b>	Inox	AISI 302	Inox	AISI 302
6 <b>Joint</b>	EPDM		EPDM	
7 <b>Obturbateur:</b>	Rp 2¼" – 2½" Rp 3" – 8"	Bronze GG25, epoxy	Rp 2¼" – 2½" Rp 3" – 8"	Bronze GG25, epoxy
8 <b>Vis:</b>	Acier galvanisé		Acier galvanisé	
9 <b>Crépine:</b>	Acier galvanisé		PP	

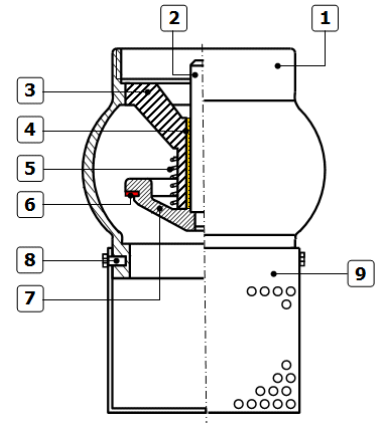

## Diagramme de débit

